

# Редукторы планетарные EPPINGER серии RT

## Технические характеристики

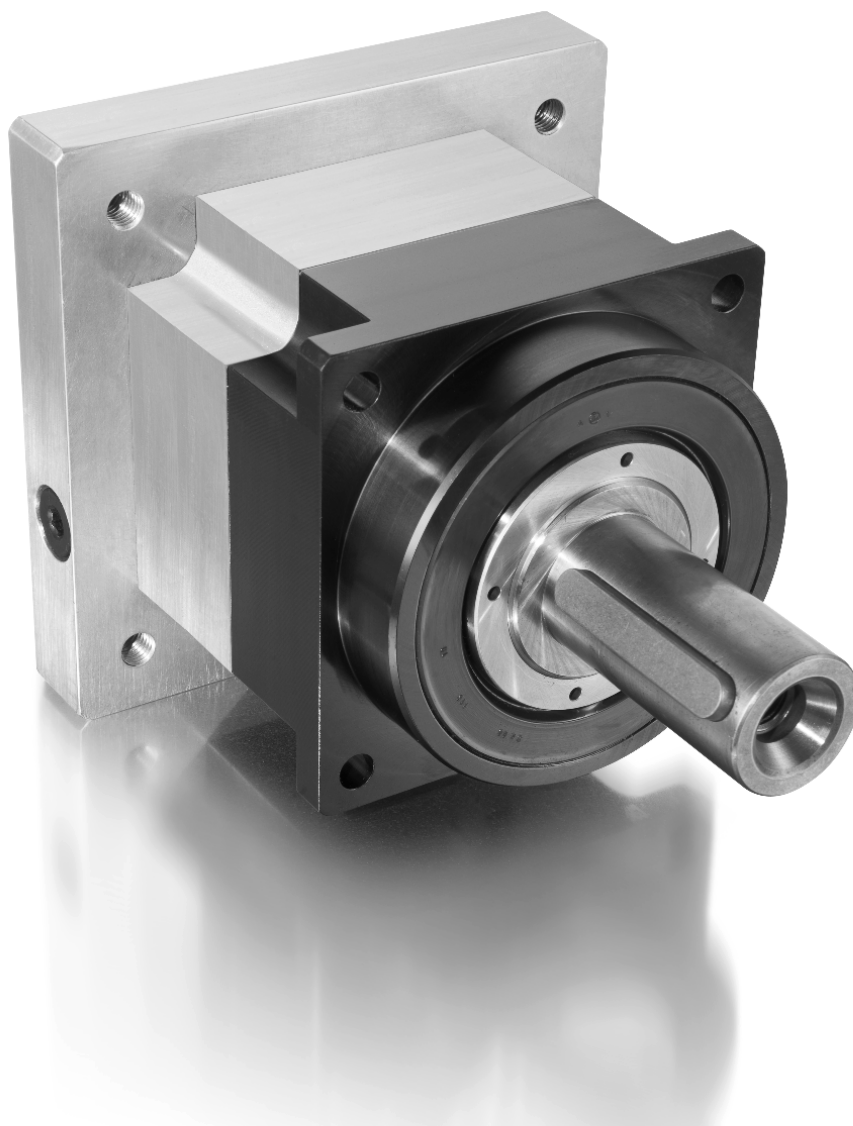

Архангельск (8182)63-90-72  
Астана (7172)727-132  
Астрахань (8512)99-46-04  
Барнаул (3852)73-04-60  
Белгород (4722)40-23-64  
Брянск (4832)59-03-52  
Владивосток (423)249-28-31  
Волгоград (844)278-03-48  
Вологда (8172)26-41-59  
Воронеж (473)204-51-73  
Екатеринбург (343)384-55-89  
Иваново (4932)77-34-06

Ижевск (3412)26-03-58  
Иркутск (395)279-98-46  
Казань (843)206-01-48  
Калининград (4012)72-03-81  
Калуга (4842)92-23-67  
Кемерово (3842)65-04-62  
Киров (8332)68-02-04  
Краснодар (861)203-40-90  
Красноярск (391)204-63-61  
Курск (4712)77-13-04  
Липецк (4742)52-20-81  
Киргизия (996)312-96-26-47

Магнитогорск (3519)55-03-13  
Москва (495)268-04-70  
Мурманск (8152)59-64-93  
Набережные Челны (8552)20-53-41  
Нижний Новгород (831)429-08-12  
Новокузнецк (3843)20-46-81  
Новосибирск (383)227-86-73  
Омск (3812)21-46-40  
Орел (4862)44-53-42  
Оренбург (3532)37-68-04  
Пенза (8412)22-31-16  
Россия (495)268-04-70

Пермь (342)205-81-47  
Ростов-на-Дону (863)308-18-15  
Рязань (4912)46-61-64  
Самара (846)206-03-16  
Санкт-Петербург (812)309-46-40  
Саратов (845)249-38-78  
Севастополь (8692)22-31-93  
Симферополь (3652)67-13-56  
Смоленск (4812)29-41-54  
Сочи (862)225-72-31  
Ставрополь (8652)20-65-13  
Казахстан (772)734-952-31

Сургут (3462)77-98-35  
Тверь (4822)63-31-35  
Томск (3822)98-41-53  
Тула (4872)74-02-29  
Тюмень (3452)66-21-18  
Ульяновск (8422)24-23-59  
Уфа (347)229-48-12  
Хабаровск (4212)92-98-04  
Челябинск (351)202-03-61  
Череповец (8202)49-02-64  
Ярославль (4852)69-52-93

# EPPINGER Planetary Gearboxes

The servo gearboxes PT complete the whole range of our servo gearboxes that consist of high-end planetary gearboxes, right angle gearboxes, hypoid gearboxes, cycloid gearboxes as well as various combinations thereof. All common servo motors can be easily installed with all sizes of our gearboxes.

Our PT servo planetary gearboxes guarantee high stiffness and reliable transmission through their unique design. All ring gears, planet gears and sun pinions are case - hardened and ground. This provides for an outstanding transmission quality and allows for precise positioning tasks.

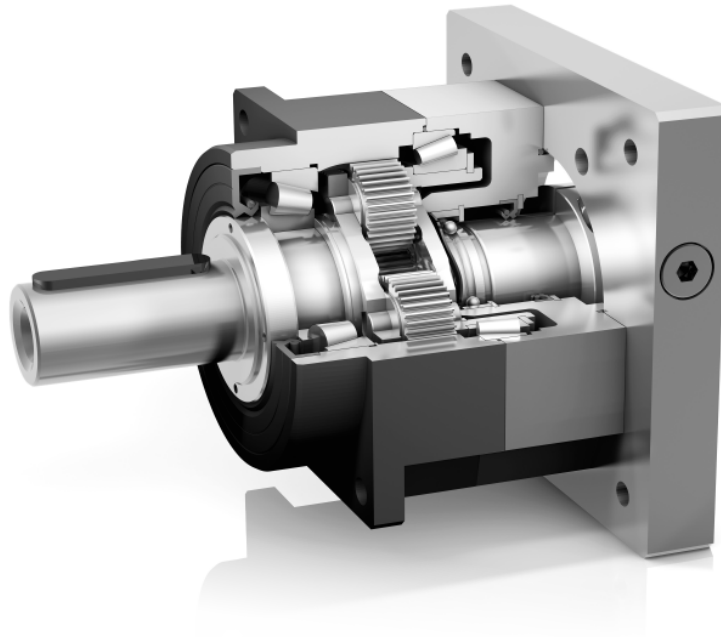

## FEATURES AND BENEFITS OF PT PLANETARY GEARBOX SERIES

- Case - hardened and ground ring gears with minimized run - out
- Case - hardened and ground planet gears and sun pinions
- High transmission quality through high-precision components
- High positioning accuracy
- High torsional stiffness
- Solid bearings
- Compact design
- High permissible axial and radial loads
- Extremely high torsional stiffness due to the use of large taper roller bearings
- Suitable for all mounting positions
- Protection class IP 64
- High permissible emergency off-torque through form-locking power transmission.
- Smooth running through optimized gear geometry
- Reduced friction due to minimized sealing diameters
- Backlash-free power transmission by force-locking motor clutch

Our product range includes **bevel-, hypoid-, planetary-, cycloid-, special customized gearboxes and high precision gear technology**. The **compact mono-bloc design** makes our solutions **unique**.

## Performance data

	Abbreviation	Unit	Ratio	PT062	PT076	PT101	PT141	PT182	PT242	Number of stages
<b>Rated output torque</b> [at nominal input speed, continuous duty loading-S1 and ambient temperature of 30°C]	T <sub>2N</sub>	Nm	i = 3 : 1	-	-	145	330	860	2150	1
			i = 4 : 1	30	100	200	500	1200	3000	
			i = 5 : 1	30	120	240	600	1450	3600	
			i = 7 : 1	30	100	200	500	1200	3000	
			i = 10 : 1	24	72	145	330	860	2150	2
			i = 20/35/40/70 : 1	30	120	200	500	1200	3000	
i = 25/50 : 1	30	120	240	600	1450	3600				
i = 100 : 1	24	72	145	330	860	2150				
<b>Max. acceleration torque</b> [allowable for max. 1000 cycles per hr with overall running time less than 5% and at impulse time within 0.3 sec]	T <sub>2B</sub>	Nm	i = 3 : 1	-	-	220	560	1440	3000	1
			i = 4 : 1	50	170	340	840	2040	5000	
			i = 5 : 1	50	200	400	1000	2400	6000	
			i = 7 : 1	50	170	340	840	2040	5000	
			i = 10 : 1	40	110	220	560	1440	3000	2
			i = 20/35/40/70 : 1	50	170	340	840	2040	5000	
i = 25/50 : 1	50	200	400	1000	2400	6000				
i = 100 : 1	40	110	220	560	1440	3000				
<b>Emergency stop torque</b> [allowable for 1000 times in service life]	T <sub>2Not</sub>	Nm	i = 3 : 1	-	-	400	840	2160	5400	1
			i = 4 : 1	100	280	560	1260	3060	7500	
			i = 5 : 1	100	330	660	1500	3600	9000	
			i = 7 : 1	80	280	560	1260	3060	7500	
			i = 10 : 1	80	200	400	840	2160	5400	2
			i = 20/35/40/70 : 1	100	280	560	1260	3060	7500	
i = 25/50 : 1	100	330	660	1500	3600	9000				
i = 100 : 1	80	200	400	840	2160	5400				
<b>Maximum input speed</b>	n <sub>1max</sub>	rpm	i = 3 : 1	-	-	4000	3200	2500	2000	1
			i = 4 : 1	5000	5000	4000	3200	2500	2000	
			i = 5 : 1	6300	6300	5000	4000	3200	2500	
			i = 7 : 1	8000	8000	6300	5000	4000	3000	
			i = 10 : 1	10000	10000	8000	6300	5000	3500	2
			i = 20/25/35 : 1	6300	6300	5000	4000	3200	3200	
i = 40 to 100 : 1	10000	10000	8000	6300	5000	5000				
<b>Rated input speed</b>	n <sub>1N</sub>	rpm	i = 3 : 1	-	-	2300	1800	1300	800	1
			i = 4 : 1	3000	3000	2500	2000	1500	1000	
			i = 5 : 1	4000	4000	3000	2500	2000	1200	
			i = 7 : 1	5000	5000	4000	3000	2500	1500	
			i = 10 : 1	6000	6000	5000	4000	3000	2000	2
			i = 20/25/35 : 1	4000	4000	3000	2500	2000	2000	
i = 40 to 100 : 1	6000	6000	5000	4000	3000	3000				
<b>Torsional backlash - standard</b>		arcmin	all ratios	≤ 6	≤ 6	≤ 4	≤ 4	≤ 4	≤ 4	1
		arcmin		≤ 8	≤ 8	≤ 6	≤ 6	≤ 6	≤ 6	2
<b>Torsional backlash - precision</b>		arcmin		≤ 3	≤ 3	≤ 2	≤ 2	≤ 2	≤ 2	1
		arcmin		≤ 6	≤ 6	≤ 4	≤ 4	≤ 4	≤ 4	2
<b>Torsional backlash - minimized</b>		arcmin					≤ 1	≤ 1	≤ 1	1
		arcmin					≤ 1	≤ 1	≤ 1	2
<b>Max. permissible radial load</b> (on output shaft middle for 15000 hrs bearing life and with output shaft speed of n <sub>2</sub> = 300 rpm)	F <sub>Rmax</sub>	N		3000	4000	7200	10000	17500	23700	all stages
<b>Max. permissible axial load</b>	F <sub>Amax</sub>	N		3400	4950	7600	10500	18500	24700	
<b>Efficiency at full load</b>	η	%				97%				1
						94%				2
<b>Operating noise</b> (on idle running with 3000 rpm input speed and i=10)	L <sub>pa</sub>	dB(A)	≤ 53	≤ 56	≤ 56	≤ 56	≤ 65	≤ 65	1	
			≤ 49	≤ 51	≤ 55	≤ 55	≤ 63	≤ 63	2	
<b>Weight</b>	m	kg			on request				all stages	
<b>Service life</b>	L <sub>h</sub>	h			> 20000					
<b>Lubrication</b>					oil filled					
<b>Minimum operating temperature</b>		°C			-10					
<b>Maximum operating temperature</b>		°C			90					
<b>Degree of protection</b>					IP 65					
<b>Mounting position</b>					any					
<b>Motor Flange</b>					optional					

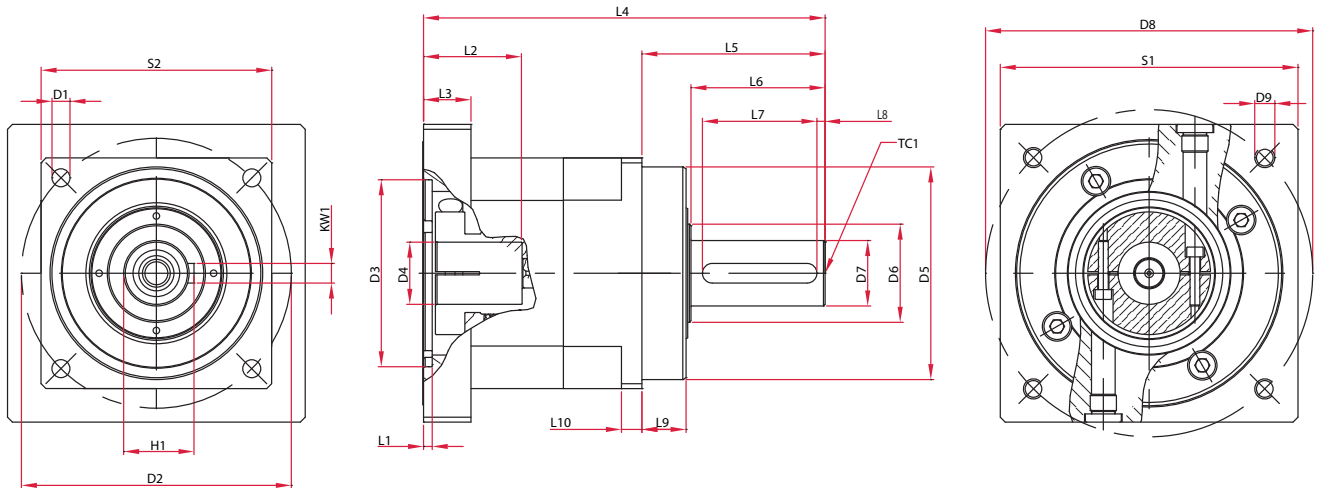

## Dimensions (in mm)

	PT062	PT076	PT101	PT141	PT182	PT242	Stages	
D1 Mounting hole - output side	5,5	6,6	9	11	13	17	all ratios	
D2 Pitch circle diameter - output side	68	85	120	165	215	290		
D3 Centering diameter - drive side	to suit motor							
D4 Bore diameter - drive shaft	max. F6	14	24	32	38	48	60	1
		14	24	32	38	38	38	2
D5 Centering diameter - output side	g6	60	70	90	130	160	200	all ratios
D6 Shaft shoulder diameter - output shaft	k6	20	28	40	60	65	95	
D7 Shaft diameter - output shaft	k6	16	22	32	40	55	85	
D8 Pitch circle diameter - drive side	to suit motor							
D9 Mounting thread - drive side	to suit motor							
H1 Key height - output shaft	18	24,5	35	43	55	90		
KW1 Key width - output shaft	5	6	10	12	16	22		
L1 Depth of centering bore - drive side	3,5	4,5	5,5	5,3	8	8		
L2 Maximum Bore depth - drive side	30	40	50	60	82	110		
L3 Flange length - drive side	to suit motor shaft length							
L4 Overall length *	148	169	230	246	330	435	1	
	165,5	196	266	299,5	359,5	678	2	
L5 Shaft length from housing face - output side	48	56	88	112	112	170	all ratios	
L6 Shaft length - output side	28	36	58	82	82	130		
L7 Key length - output shaft	22	28	50	70	70	110		
L8 Key position from shaft end - output side	3	4	4	5	5	7,5		
L9 Spigot length - output side	18	18	28	27	27	37		
L10 Flange length - output side	8	8	10	12,5	22	30		
S1 Flange size - drive side	to suit motor							
S2 Flange size - output side	62	80	101	141	182	242		
TC1 Centre hole to DIN332 - output side	M5x12	M8x19	M12x28	M16x36	M20x42	M20x42		

\* - value indicated is with L2 given above and overall length depends on motor shaft length

Subject to change in design. We recommend technical clarification prior to ordering.

Архангельск (8182)63-90-72  
Астана (7172)727-132  
Астрахань (8512)99-46-04  
Барнаул (3852)73-04-60  
Белгород (4722)40-23-64  
Брянск (4832)59-03-52  
Владивосток (423)249-28-31  
Волгоград (844)278-03-48  
Вологда (8172)26-41-59  
Воронеж (473)204-51-73  
Екатеринбург (343)384-55-89  
Иваново (4932)77-34-06

Ижевск (3412)26-03-58  
Иркутск (395)279-98-46  
Казань (843)206-01-48  
Калининград (4012)72-03-81  
Калуга (4842)92-23-67  
Кемерово (3842)65-04-62  
Киров (8332)68-02-04  
Краснодар (861)203-40-90  
Красноярск (391)204-63-61  
Курск (4712)77-13-04  
Липецк (4742)52-20-81  
Киргизия (996)312-96-26-47

Магнитогорск (3519)55-03-13  
Москва (495)268-04-70  
Мурманск (8152)59-64-93  
Набережные Челны (8552)20-53-41  
Нижний Новгород (831)429-08-12  
Новокузнецк (3843)20-46-81  
Новосибирск (383)227-86-73  
Омск (3812)21-46-40  
Орел (4862)44-53-42  
Оренбург (3532)37-68-04  
Пенза (8412)22-31-16  
Россия (495)268-04-70

Пермь (342)205-81-47  
Ростов-на-Дону (863)308-18-15  
Рязань (4912)46-61-64  
Самара (846)206-03-16  
Санкт-Петербург (812)309-46-40  
Саратов (845)249-38-78  
Севастополь (8692)22-31-93  
Симферополь (3652)67-13-56  
Смоленск (4812)29-41-54  
Сочи (862)225-72-31  
Ставрополь (8652)20-65-13  
Казахстан (772)734-952-31

Сургут (3462)77-98-35  
Тверь (4822)63-31-35  
Томск (3822)98-41-53  
Тула (4872)74-02-29  
Тюмень (3452)66-21-18  
Ульяновск (8422)24-23-59  
Уфа (347)229-48-12  
Хабаровск (4212)92-98-04  
Челябинск (351)202-03-61  
Череповец (8202)49-02-64  
Ярославль (4852)69-52-93