

Редукторы планетарные EPPINGER серии PE, PBE

Технические характеристики

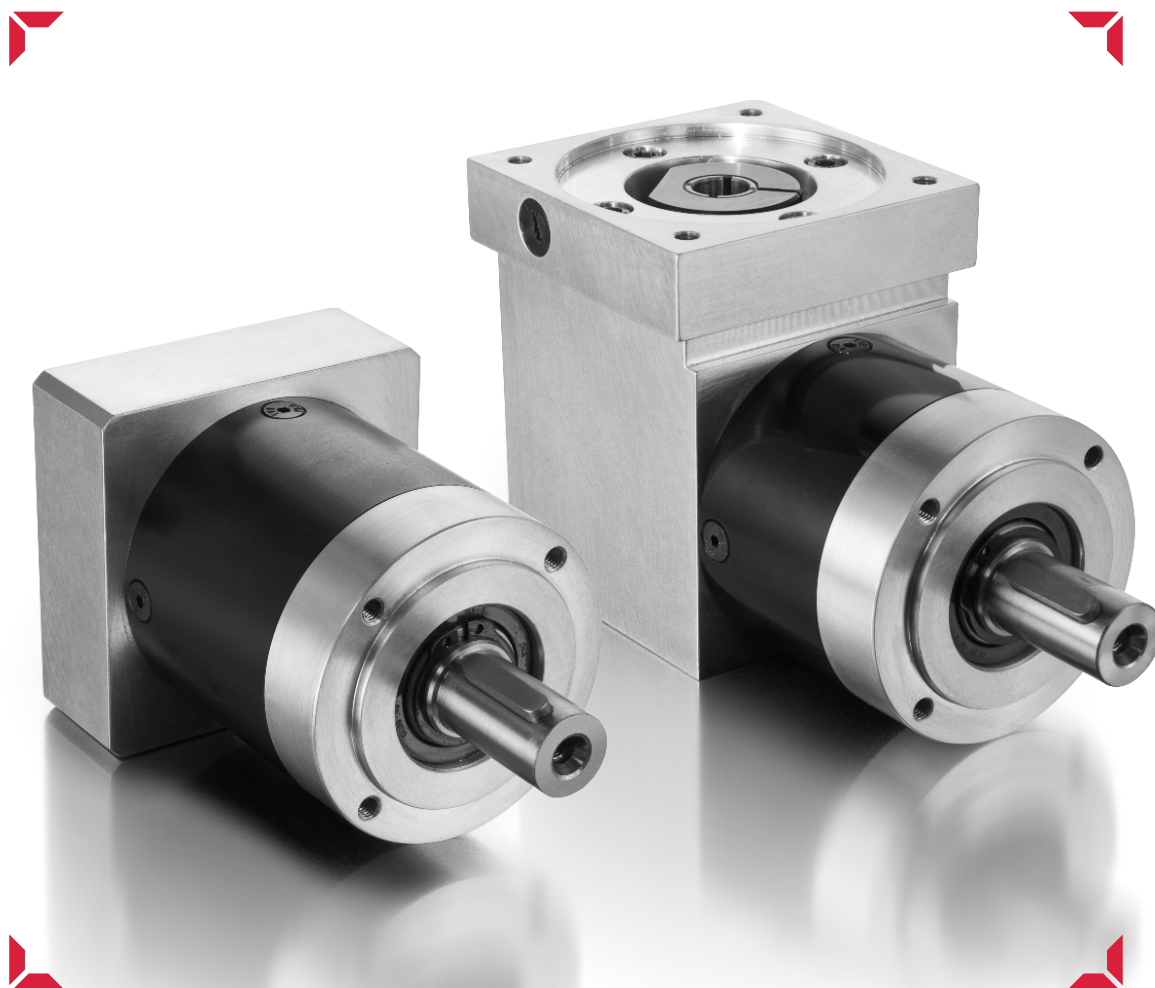

Архангельск (8182)63-90-72
Астана (7172)727-132
Астрахань (8512)99-46-04
Барнаул (3852)73-04-60
Белгород (4722)40-23-64
Брянск (4832)59-03-52
Владивосток (423)249-28-31
Волгоград (844)278-03-48
Вологда (8172)26-41-59
Воронеж (473)204-51-73
Екатеринбург (343)384-55-89
Иваново (4932)77-34-06

Ижевск (3412)26-03-58
Иркутск (395)279-98-46
Казань (843)206-01-48
Калининград (4012)72-03-81
Калуга (4842)92-23-67
Кемерово (3842)65-04-62
Киров (8332)68-02-04
Краснодар (861)203-40-90
Красноярск (391)204-63-61
Курск (4712)77-13-04
Липецк (4742)52-20-81
Киргизия (996)312-96-26-47

Магнитогорск (3519)55-03-13
Москва (495)268-04-70
Мурманск (8152)59-64-93
Набережные Челны (8552)20-53-41
Нижний Новгород (831)429-08-12
Новокузнецк (3843)20-46-81
Новосибирск (383)227-86-73
Омск (3812)21-46-40
Орел (4862)44-53-42
Оренбург (3532)37-68-04
Пенза (8412)22-31-16
Россия (495)268-04-70

Пермь (342)205-81-47
Ростов-на-Дону (863)308-18-15
Рязань (4912)46-61-64
Самара (846)206-03-16
Санкт-Петербург (812)309-46-40
Саратов (845)249-38-78
Севастополь (8692)22-31-93
Симферополь (3652)67-13-56
Смоленск (4812)29-41-54
Сочи (862)225-72-31
Ставрополь (8652)20-65-13
Казахстан (772)734-952-31

Сургут (3462)77-98-35
Тверь (4822)63-31-35
Томск (3822)98-41-53
Тула (4872)74-02-29
Тюмень (3452)66-21-18
Ульяновск (8422)24-23-59
Уфа (347)229-48-12
Хабаровск (4212)92-98-04
Челябинск (351)202-03-61
Череповец (8202)49-02-64
Ярославль (4852)69-52-93

EPPINGER Planetary Gearboxes

The planetary gearboxes PE complete the whole range of our automation gearbox series consisting of high-end planetary gearboxes, right angle gearboxes, hypoid gearboxes, cycloid gearboxes as well as various combinations thereof. The right angle

gearbox PBE rounds off this series with its pre-stage bevel gearbox. Smooth running is achieved through the use of Gleason type spiral bevel gears in the pre-stage of the gearbox.

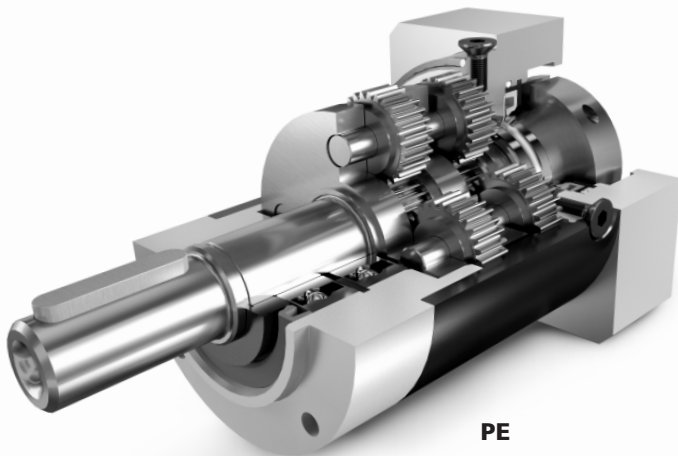

PE

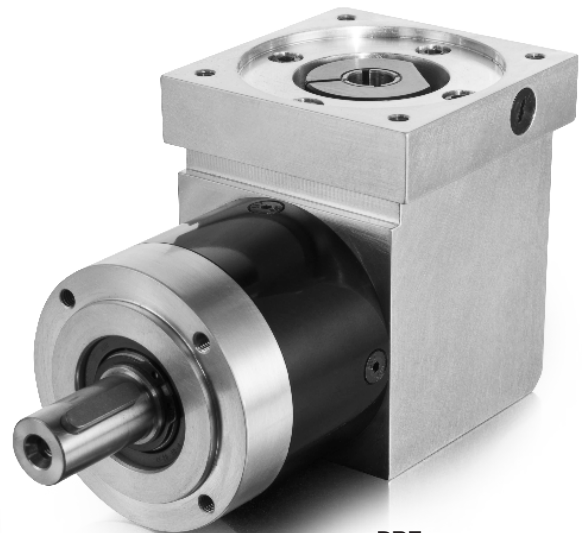

PBE

FEATURES AND BENEFITS OF PE / PBE PLANETARY GEARBOX SERIES

PE

- Case - hardened and ground ring gears
- Case - hardened and ground planet gears and sun pinions guarantee high transmission quality and long lifetime
- Low Backlash
- Easiest mounting of motor through flexible flange system
- High flexibility with proven hollow drive shaft system
- Integrated axial length compensation to compensate for thermal expansion of the motor shaft
- High efficiency and smooth running through high tooth flank quality, planet gears with needle roller bearings and high quality lubricant
- High torsional stiffness and high emergency off torque through robust design and optimized gear geometry
- Four sizes of gearboxes for output torques between 4-270Nm
- Available ratios from $i=3$ to $i=512$
- Lifetime lubrication
- Universal mounting positions
- Protection class IP64

PBE

- Case - hardened and ground ring gears
- Case - hardened and ground planet gears and sun pinions guarantee high transmission quality and long lifetime
- Low Backlash
- Easiest mounting of motor through flexible flange system
- High flexibility with proven hollow drive shaft system
- Integrated axial length compensation to compensate for thermal expansion of the motor shaft
- High efficiency and smooth running through high tooth flank quality, planet gears with needle roller bearings and high quality lubricant
- High torsional stiffness and high emergency off torque through robust design and optimized gear geometry
- Four sizes of gearboxes for output torques between 4-270Nm
- Available ratios from $i=3$ to $i=512$
- Lifetime lubrication
- Universal mounting positions
- Protection class IP64
- Smooth running achieved through the use of spiral bevel gears (Gleason type)

Performance data

	Abbreviation	Unit	Ratio	PE040 PBE040	PE060 PBE060	PE080 PBE080	PE120 PBE120	Number of stages
Rated output torque [for 100 rpm speed of output shaft, electrical motor drive, continuous duty loading-S1 and ambient temperature of 30°C]	T _{2N}	Nm	i = 3 : 1	11	30	95	160	1
			i = 4 : 1	16	40	125	160	
			i = 5 : 1	16	40	115	200	
			i = 7 : 1	9	30	70	140	
			i = 8 : 1	7	20	55	120	
			i = 10 : 1	6	16	45	95	
			i = 9 : 1	18	46	125	230	2
			i = 12 : 1	18	46	125	270	
			i = 15 : 1	18	46	115	270	
			i = 16 : 1	21	46	125	270	
			i = 20 : 1	21	46	125	270	
			i = 25 : 1	21	46	115	270	
			i = 32 : 1	21	46	125	270	3
			i = 40 : 1	21	46	115	270	
			i = 64 : 1	8	20	55	120	
			i = 60 : 1	21	46	115	270	
			i = 80 : 1	21	46	125	270	
			i = 100 : 1	21	46	125	270	
i = 120 : 1	21	46	125	270	3			
i = 160 : 1	21	46	125	270				
i = 200 : 1	21	46	115	270				
i = 256 : 1	21	46	125	270				
i = 320 : 1	21	46	115	270				
i = 512 : 1	8	20	55	120/140				
Max. acceleration torque [allowable for 30000 revolutions with conditions same as given for nominal torque]	T _{2B}	Nm	all ratios	1,6 x T _{2N}				all stages
Emergency stop torque [allowable for 1000 times in service life]	T _{2Not}	Nm		2 x T _{2N}				
Rated input speed	n _{1N}	rpm		5000	4500	4000	3500	
Maximum input speed	n _{1max}	rpm		6500	6500	6500	6500	
Torsional backlash - standard (PE)		arcmin		≤ 14	≤ 9	≤ 7	≤ 6	1
				≤ 18	≤ 11	≤ 9	≤ 8	2
				≤ 21	≤ 14	≤ 11	≤ 10	3
Torsional backlash - standard (PBE)		arcmin		≤ 20	≤ 15	≤ 12	≤ 10	1
				≤ 24	≤ 17	≤ 14	≤ 12	2
				≤ 28	≤ 20	≤ 16	≤ 14	3
Max. permissible radial load ¹	F _{Rmax}	N	165	350	750	1600	all stages	
Max. permissible axial load ¹	F _{Amax}	N	165	450	900	2200		
Max. permissible radial load ²	F _{Rmax}	N	210	415	800	1820	all stages	
Max. permissible axial load ²	F _{Amax}	N	210	525	1050	2650		
Torsional stiffness		Nm/ arcmin	1,02	2,35	6,12	12,20	1	
			1,09	2,52	6,52	12,55	2	
			1,02	2,50	6,35	12,22	3	
Efficiency at full load	η	%	PE 96% / PBE 94%				1	
			PE 94% / PBE 92%				2	
			PE 91% / PBE 90%				3	
Operating noise measured at 1m distance (on idle running with 3000 rpm input speed and i=5)	L _{pa}	dB(A)	PE ≤ 60 PBE ≤ 70	PE ≤ 60 PBE ≤ 72	PE ≤ 65 PBE ≤ 75	PE ≤ 68 PBE ≤ 76	all stages	
Weight PE	m	kg	0,4	1,0	2,3	7	1	
			0,5	1,2	2,8	10	2	
			0,6	1,5	3,4	12	3	
Weight PBE	m	kg	upon request				all stages	
Service life	L _h	h	> 30000					
Lubrication			grease packed					
Minimum operating temperature		°C	-25					
Maximum operating temperature		°C	90					
Degree of protection			IP 64					
Mounting position			any					
Motor flange			optional					

¹ on output shaft middle for 30000 hrs bearing life and conditions in T_{2N}

² on output shaft middle for 20000 hrs bearing life and conditions in T_{2N}

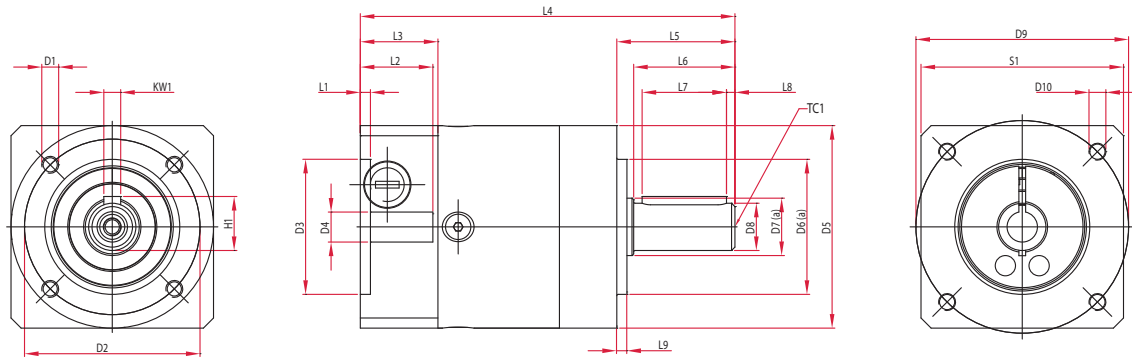

Option: Free input shaft

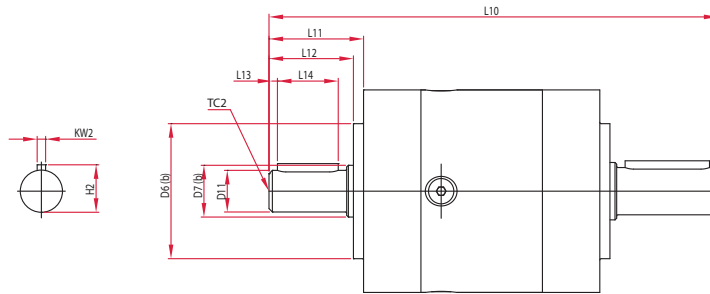

PE dimensions (in mm)

	PE040	PE060	PE080	PE120	Stages
D1 Mounting thread- output side	M4x6	M5x8	M6x10	M10x16	all stages
D2 Pitch circle diameter - output side	34	52	70	100	
D3 Centering diameter - drive side	to suit motor				
D4 Bore diameter- drive shaft (maximum)	11	14	19	35	
D5 Outer diameter	42	60	80	120	
D6(a) Centering diameter - output side	26	40	60	80	
D6(b) Centering diameter - input side	26	40	60	80	
D7(a) Shaft shoulder diameter - output shaft	12	17	25	35	
D7(b) Shaft shoulder diameter - input shaft	12	17	25	35	
D8 Shaft diameter- output shaft	10	14	20	25	
D9 Pitch circle diameter- drive side	to suit motor				
D10 Mounting thread - drive side	to suit motor				
D11 Shaft diameter - drive shaft	8	10	16	20	
H1 Key height- output shaft	11,2	16	22,5	28	
H2 Key height- drive shaft	8,8	11,2	18	22,5	
KW1 Key width- output shaft	3	5	6	8	
KW2 Key width- drive shaft	2	3	5	6	
L1 Depth of centering bore - drive side	to suit motor				
L2 Bore depth- drive side	to suit motor				
L3 Flange length - drive side	to suit motor				
L4 Overall length (for IP64)	to suit motor				
L5 Shaft length from housing face - output side	26	35	40	56	
L6 Shaft length from spigot - output side	23	30	36	50	
L7 Key length - output shaft	18	25	28	40	
L8 Key position from shaft end - output side	2,5	3	4	5	
L9 Spigot length - output side	2	3	3	5	
L10 Overall length (IP64)	upon request				
L11 Shaft length from housing face - drive side	20	28	30	45	
L12 Shaft length from spigot - drive side	17	23	26	40	
L13 Key position from shaft end - drive side	2,5	2,5	3	4	
L14 Key length - drive shaft	12	18	20	32	
S1 Flange size - drive side	to suit motor				
TC1 Centre hole to DIN332 - output side	M3x9	M5x12	M6x16	M10x22	
TC2 Centre hole to DIN332 - drive side	M3x9	M3x9	M5x12	M6x16	

We recommend technical clarification prior to ordering.

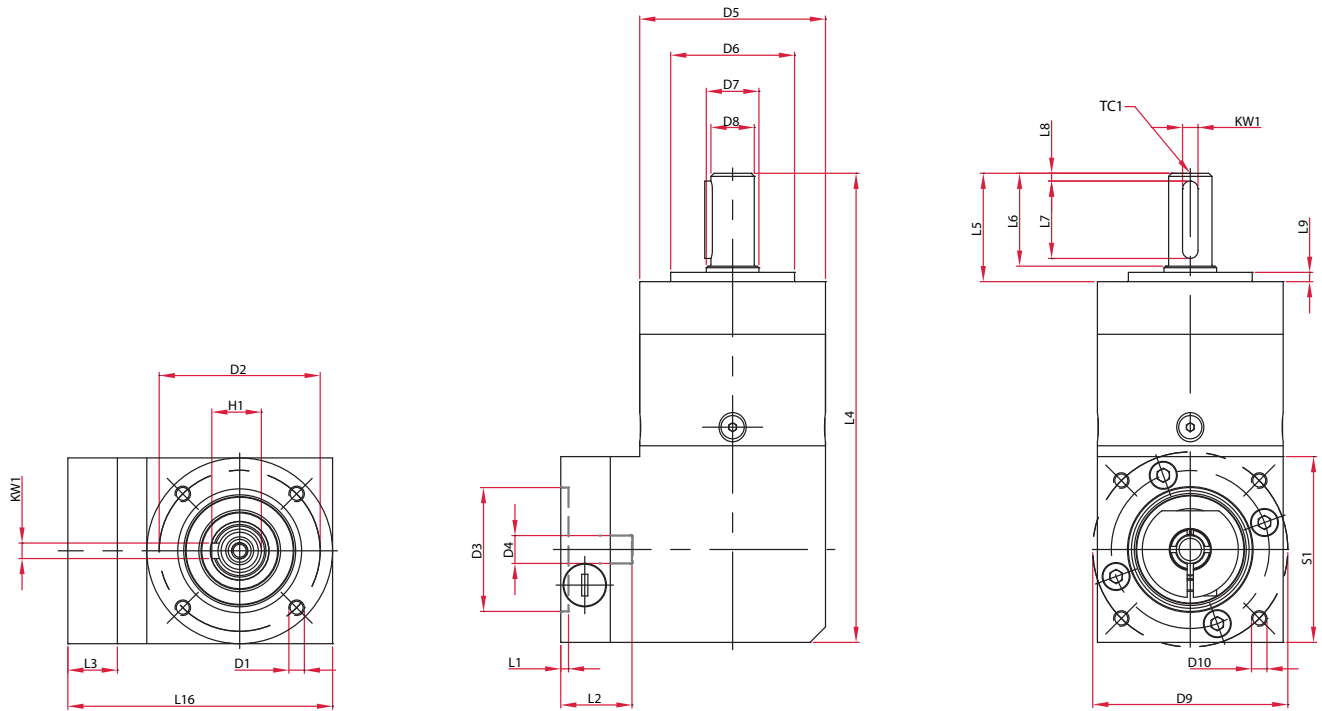

PBE dimensions (in mm)

		PBE040	PBE060	PBE080	PBE120	Stages
D1	Mounting thread- output side	M4x6	M5x8	M6x10	M10x16	all stages
D2	Pitch circle diameter - output side	34	52	70	100	
D3	Centering diameter - drive side	to suit motor				
D4	Bore diameter- drive shaft (maximum)	11	14	19	35	
D5	Outer diameter	42	60	80	120	
D6	Centering diameter - output side	26	40	60	80	
D7	Shaft shoulder diameter	12	17	25	35	
D8	Shaft diameter - output side	10	14	20	25	
D9	Pitch circle diameter - drive side	to suit motor				
D10	Mounting thread - drive side	to suit motor				
H1	Key height - output shaft	11,2	16	22,5	28	
KW1	Key width-output shaft	3	5	6	8	
L1	Depth of centering bore - drive side	to suit motor				
L2	Bore depth- drive side	to suit motor				
L3	Flange length - drive side	to suit motor				
L4	Overall length (for IP64)	135	154	192	298	
		150	169	207	321	2
		164	184	222	343	3
L5	Shaft length from housing face - output side	26	35	40	56	all stages
L6	Shaft length from spigot - output side	23	30	36	50	
L7	Key length - output shaft	18	25	28	40	
L8	Key position from shaft end - output side	2,5	3	4	5	
L9	Spigot length - output side	2	3	3	4	
L16	Height of gearbox - drive side	to suit motor				
S1	Flange size - drive side	to suit motor				
TC1	Centre hole to DIN332 - output side	M3x9	M5x12	M6x16	M10x22	

We recommend technical clarification prior to ordering.

Архангельск (8182)63-90-72
Астана (7172)727-132
Астрахань (8512)99-46-04
Барнаул (3852)73-04-60
Белгород (4722)40-23-64
Брянск (4832)59-03-52
Владивосток (423)249-28-31
Волгоград (844)278-03-48
Вологда (8172)26-41-59
Воронеж (473)204-51-73
Екатеринбург (343)384-55-89
Иваново (4932)77-34-06

Ижевск (3412)26-03-58
Иркутск (395)279-98-46
Казань (843)206-01-48
Калининград (4012)72-03-81
Калуга (4842)92-23-67
Кемерово (3842)65-04-62
Киров (8332)68-02-04
Краснодар (861)203-40-90
Красноярск (391)204-63-61
Курск (4712)77-13-04
Липецк (4742)52-20-81
Киргизия (996)312-96-26-47

Магнитогорск (3519)55-03-13
Москва (495)268-04-70
Мурманск (8152)59-64-93
Набережные Челны (8552)20-53-41
Нижний Новгород (831)429-08-12
Новокузнецк (3843)20-46-81
Новосибирск (383)227-86-73
Омск (3812)21-46-40
Орел (4862)44-53-42
Оренбург (3532)37-68-04
Пенза (8412)22-31-16
Россия (495)268-04-70

Пермь (342)205-81-47
Ростов-на-Дону (863)308-18-15
Рязань (4912)46-61-64
Самара (846)206-03-16
Санкт-Петербург (812)309-46-40
Саратов (845)249-38-78
Севастополь (8692)22-31-93
Симферополь (3652)67-13-56
Смоленск (4812)29-41-54
Сочи (862)225-72-31
Ставрополь (8652)20-65-13
Казахстан (772)734-952-31

Сургут (3462)77-98-35
Тверь (4822)63-31-35
Томск (3822)98-41-53
Тула (4872)74-02-29
Тюмень (3452)66-21-18
Ульяновск (8422)24-23-59
Уфа (347)229-48-12
Хабаровск (4212)92-98-04
Челябинск (351)202-03-61
Череповец (8202)49-02-64
Ярославль (4852)69-52-93