

Редукторы гипоидные EPPINGER серии НТ

Технические характеристики

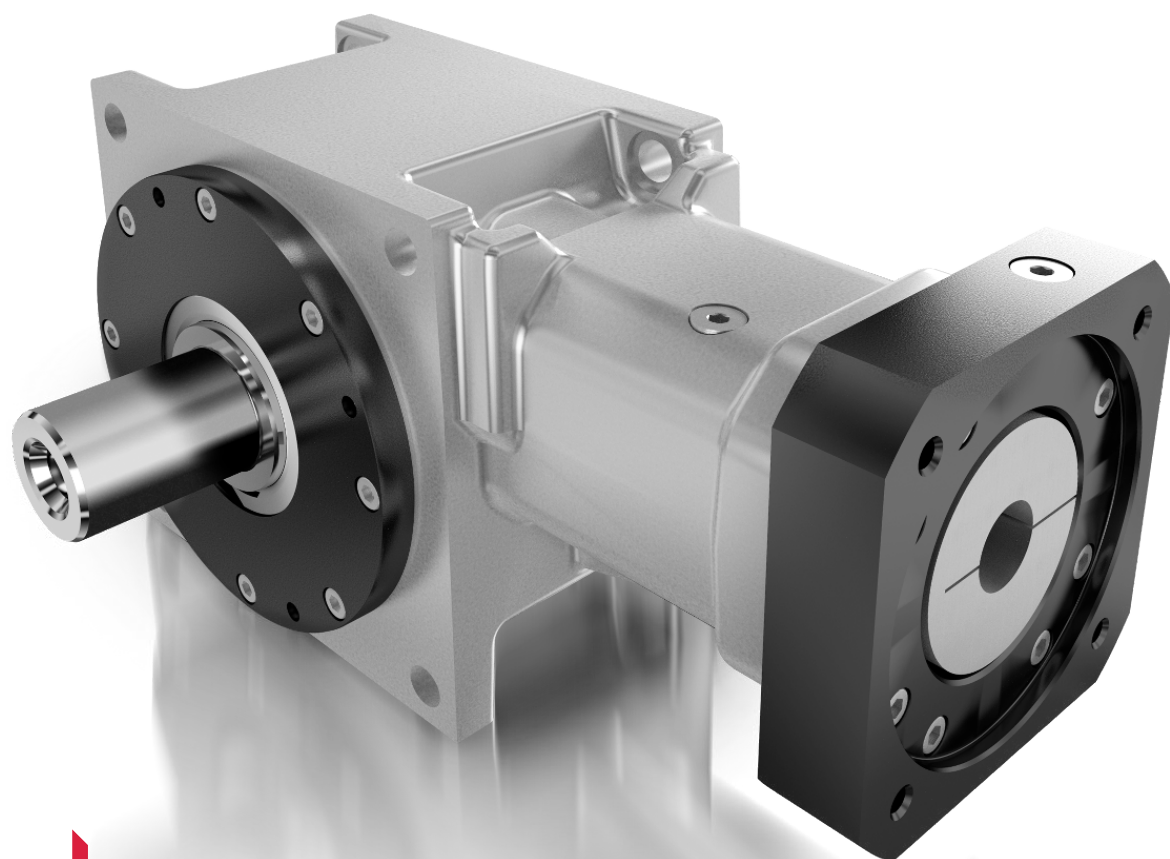

Архангельск (8182)63-90-72
Астана (7172)727-132
Астрахань (8512)99-46-04
Барнаул (3852)73-04-60
Белгород (4722)40-23-64
Брянск (4832)59-03-52
Владивосток (423)249-28-31
Волгоград (844)278-03-48
Вологда (8172)26-41-59
Воронеж (473)204-51-73
Екатеринбург (343)384-55-89
Иваново (4932)77-34-06

Ижевск (3412)26-03-58
Иркутск (395)279-98-46
Казань (843)206-01-48
Калининград (4012)72-03-81
Калуга (4842)92-23-67
Кемерово (3842)65-04-62
Киров (8332)68-02-04
Краснодар (861)203-40-90
Красноярск (391)204-63-61
Курск (4712)77-13-04
Липецк (4742)52-20-81
Киргизия (996)312-96-26-47

Магнитогорск (3519)55-03-13
Москва (495)268-04-70
Мурманск (8152)59-64-93
Набережные Челны (8552)20-53-41
Нижний Новгород (831)429-08-12
Новокузнецк (3843)20-46-81
Новосибирск (383)227-86-73
Омск (3812)21-46-40
Орел (4862)44-53-42
Оренбург (3532)37-68-04
Пенза (8412)22-31-16
Россия (495)268-04-70

Пермь (342)205-81-47
Ростов-на-Дону (863)308-18-15
Рязань (4912)46-61-64
Самара (846)206-03-16
Санкт-Петербург (812)309-46-40
Саратов (845)249-38-78
Севастополь (8692)22-31-93
Симферополь (3652)67-13-56
Смоленск (4812)29-41-54
Сочи (862)225-72-31
Ставрополь (8652)20-65-13
Казахстан (772)734-952-31

Сургут (3462)77-98-35
Тверь (4822)63-31-35
Томск (3822)98-41-53
Тула (4872)74-02-29
Тюмень (3452)66-21-18
Ульяновск (8422)24-23-59
Уфа (347)229-48-12
Хабаровск (4212)92-98-04
Челябинск (351)202-03-61
Череповец (8202)49-02-64
Ярославль (4852)69-52-93

EPPINGER hypoid gear boxes

The compact and robust design of the hypoid precision gearboxes is suitable for specific and highly dynamic applications. Our specially developed mono-bloc housing distinguishes this series with

extreme stability and provides maximum precision and efficiency. The highly flexible flange and coupling system enables our gearboxes to be connected to a host of servo motors without difficulty.

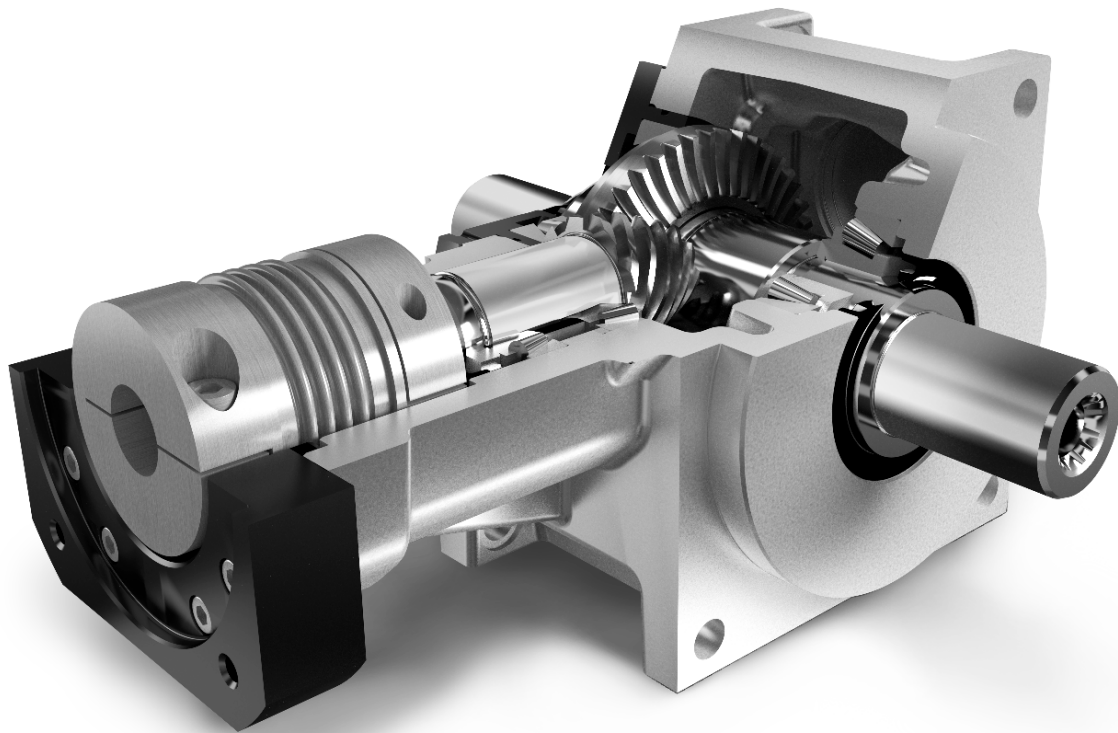

FEATURES AND BENEFITS OF THE NEW HYPOID GEAR BOX SERIES

THE HOUSING:

- Aluminum housing with high precision bearing seats and an integrated and via housing rip reinforced input neck which ensures a secure motor connection
- High power density of the gearboxes through compact housing dimensions
- Highly flexible gearbox interface via the motor flange for connecting all common servo motors
- Screw holes in the housing edges enable a stabil connection of the gearbox for various installation positions

THE GEARS:

- Hypoid gears with high load capacity, designed and manufactured according to the Gleason process stand for optimal gearing efficiency, high transmission accuracy and reduced bearing load
- Reliable torque transmission through friction-locked, backlash-free connection of the crown gears on the output shaft
- Precise gear settings through measuring of the gear components and 100% running test in assembly

- The tooth flanks are ground to achieve maximum demands on transmission performance at minimal tooth clearance

SHAFTS AND BEARINGS:

- The mono-bloc housing offers maximum stability and exact positioning of the bearing seats to each other
- Steel alloy shafts with super-finished bearing seats as basis for precise and heavy duty taper roller bearing
- Precise positioning and setting of bearings through the use of ground steel shims and interlocked bearing inner rings

THE RANGE OF GEAR BOXES:

- At present 5 gearbox sizes are available in the ratio range $i = 5 : 1$ to $15 : 1$ (other ratios available upon request)
- Hypoid gearboxes available with solid and hollow shaft for shrink disc connection with selectable output side
- Design with robot flange upon request

Performance data

	Abbreviation	Unit	HT090	HT115	HT140	HT170	HT215
Ratio ¹	i		5:1 8:1 12:1 15:1 6:1 10:1	5:1 8:1 12:1 15:1 6:1 10:1	5:1 8:1 12:1 15:1 6:1 10:1	5:1 8:1 12:1 15:1 6:1 10:1	5:1 8:1 12:1 15:1 6:1 10:1
Rated output torque	T _{2N}	Nm	38 38 30 25	75 75 60 50	150 150 120 95	280 280 225 180	720 720 580 470
Max. acceleration torque ²	T _{2B}	Nm	57 57 45 38	113 113 90 75	225 225 180 143	420 420 338 270	1080 1080 870 705
Emergency stop torque ³	T _{2Not}	Nm	76 76 60 50	150 150 120 100	300 300 240 190	560 560 450 360	1440 1440 1160 940
Rated input speed	n _{1N}	U/min	2600 3100 3700 4000	2200 2600 3100 3400	1800 2100 2600 2800	1400 1700 2100 2400	900 1200 1400 1800
Max. input speed	n _{1max}	U/min	8000	8000	7000	6000	5000
Torsional backlash - standard ⁴		arcmin	< 6	< 6	< 5	< 5	< 5
Torsional backlash - minimized ⁴		arcmin	< 3	< 3	< 2	< 2	< 2
Max. permissible radial load ⁵	F _{R2max}	N	3.500	5.000	7.500	10.000	15.000
Max. permissible axial load	F _{A2max}	N	1.700	2.500	3.500	5.000	7.500
Efficiency at rated load	η	%	91 - 98				
Operating noise	L _{pa}	db(A)	< 66	< 68	< 68	< 70	< 70
Service life	L _h	h	> 20.000				
Lubrication			Synthetic oil, ISO VG 150				
Operating temperature		°C	-20 to 90				
Weight ⁶	m	kg	3,4	5,6	9,7	15,6	34,6
Mass moment of inertia ⁷	J ₁	kgcm ²	Upon request				
Torsional stiffness ⁴	C _t	Nm/arcmin	Upon request				

¹ other ratios available upon request

² max. 1000 cycles per hour

³ max. 1000x permissible short overload peaks during service life of gearbox

⁴ referred to the output

⁵ related to center of the shaft ends

⁶ without motor flange

⁷ referred to the input shaft

Motor connection via motor flange system

	HT090	HT115	HT140	HT170	HT215
□F ¹	65 - 90	80 - 115	90 - 140	95 - 160	125 - 190
Ø D1 ¹	9 11 14 19	11 14 19 24	14 19 24 32	19 24 32	24 32 38
Ø D6	motor-specific	motor-specific	motor-specific	motor-specific	motor-specific
Ø D7	motor-specific	motor-specific	motor-specific	motor-specific	motor-specific
L10	motor-specific	motor-specific	motor-specific	motor-specific	motor-specific
L11	38 38 38 43	43 43 43 53	58 58 58 62	56 56 62	70 83 90
L13 ²	190 190 190 195	234 234 234 244	270 270 270 280	312 312 317	393 408 413
L14	21 21 21 26	25 25 25 35	30 30 30 40	32 32 37	52 65 72
T3	motor-specific	motor-specific	motor-specific	motor-specific	motor-specific

¹ other dimensions on request

² exact dimensions on gearbox datasheet

Solid Shaft Design

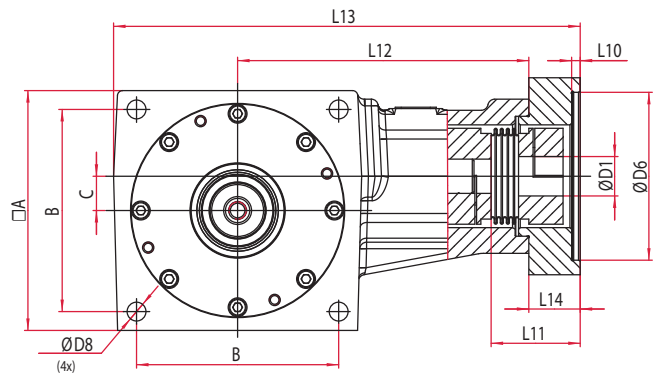
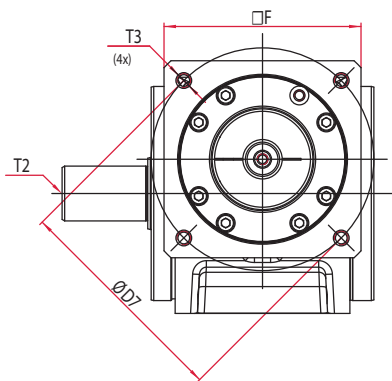
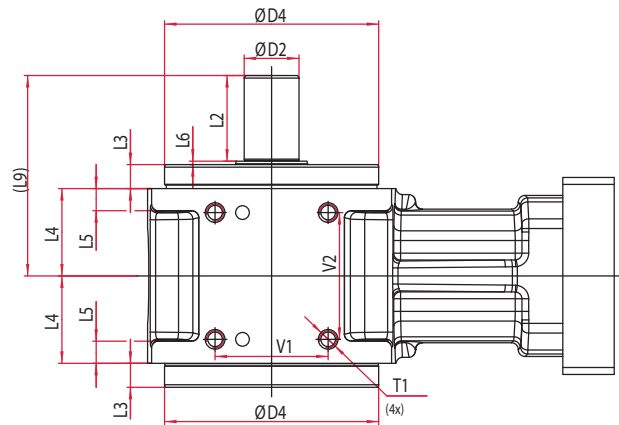
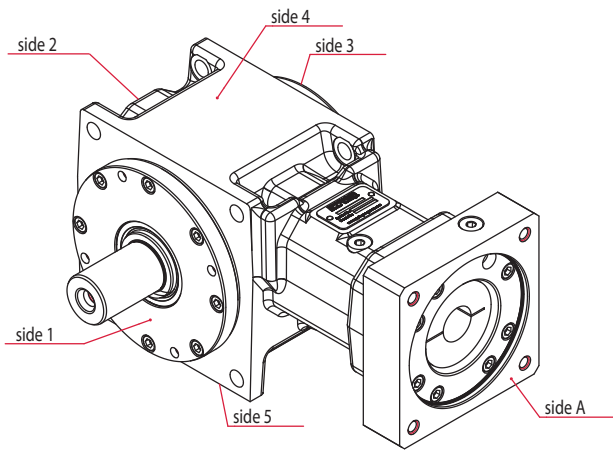

Solid Shaft Design (dimensions in mm)

	HT090	HT115	HT140	HT170	HT215
□A	90	115	140	170	215
B	78	98	118	144	182
C	10	15	20	25	34
Ø D2	20 k6	24 k6	32 k6	40 k6	55 k6
Ø D4	89 g7	105 g7	125 g7	150 g7	195 g7
Ø D8	6,6	9	11	13,5	17,5
L2	35	40	50	60	90
L3	12	12	14	14	16
L4	36	42	51	59	79
L5	9	11	13	16	19
L6	2	2	2	2	2
L9	85	96	117	135	187
L12	123	150	170	197	232
T1	M6 x 8	M8 x 16	M10 x 20	M12 x 24	M16 x 28
T2*	M6	M8	M10	M16	M20
V1	44	54	66	80	104
V2	54	60	74	86	125

* Centering bore shaft end acc. to form DS, DIN 332

Hollow Shaft Design

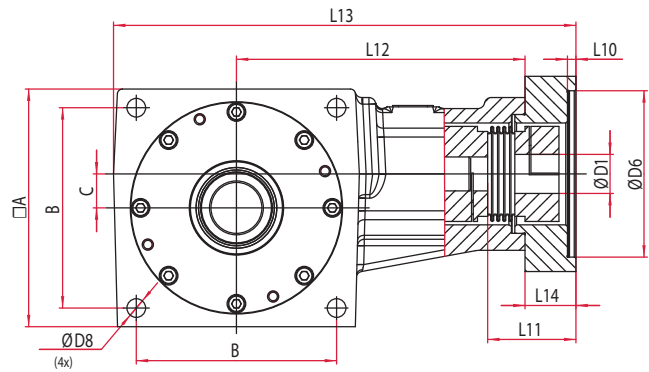
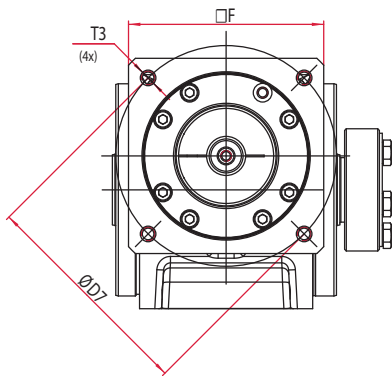
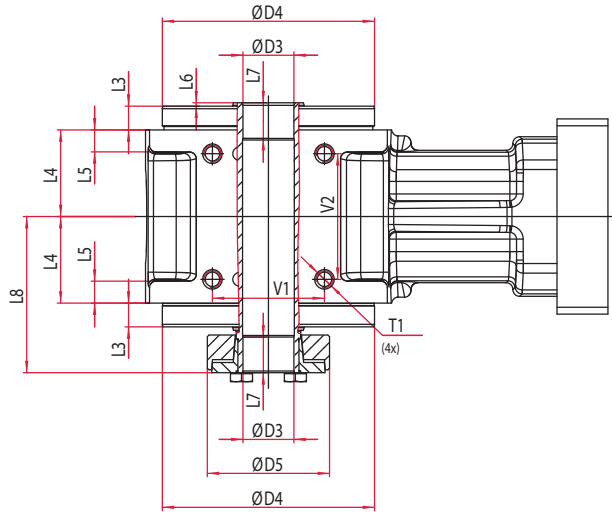
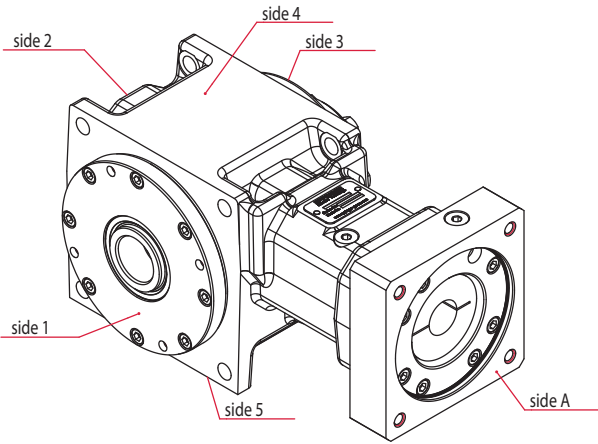

Hollow Shaft Design (dimensions in mm)

	HT090	HT115	HT140	HT170	HT215
□A	90	115	140	170	215
B	78	98	118	144	182
C	10	15	20	25	34
Ø D3	20 H7	25 H7	30 H7	40 H7	55 H7
Ø D4	89 g7	105 g7	125 g7	150 g7	195 g7
Ø D5	50	60	72	90	115
Ø D8	6,6	9	11	13,5	17,5
L3	12	12	14	14	16
L4	36	42	51	59	79
L5	9	11	13	16	19
L6	2	2	2	2	2
L7	17	19	21	25	28
L8	69	78	92	104	130
L12	123	150	170	197	232
T1	M6 x 8	M8 x 16	M10 x 20	M12 x 24	M16 x 28
V1	44	54	66	80	104
V2	54	60	74	86	125

EPPINGER precision gear boxes at a glance

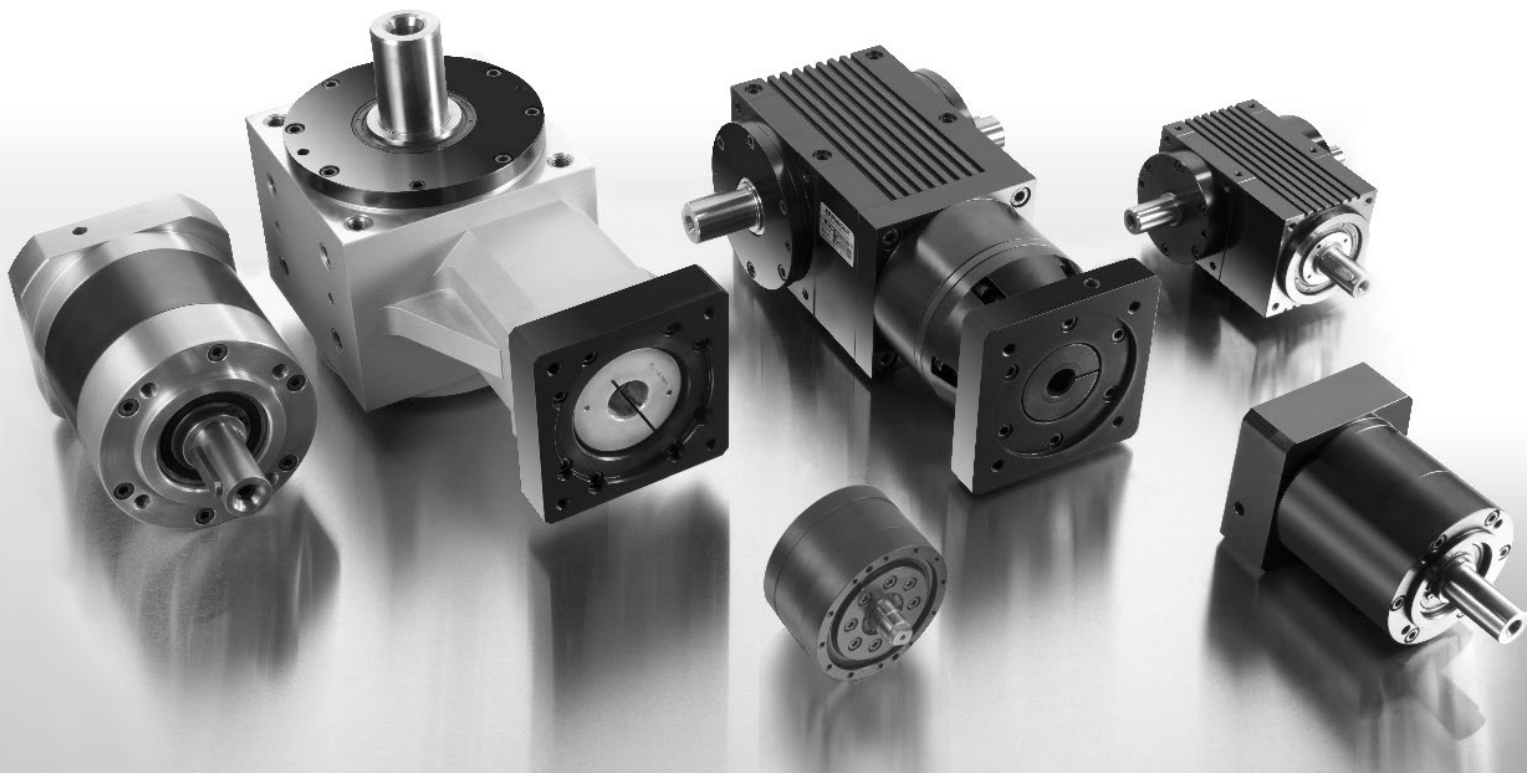

Our product range includes **bevel-, hypoid-, planetary-, cycloid-, special customized gearboxes and high precision gear technology**. The **compact mono-bloc design** makes our solutions **unique**.

Архангельск (8182)63-90-72
Астана (7172)727-132
Астрахань (8512)99-46-04
Барнаул (3852)73-04-60
Белгород (4722)40-23-64
Брянск (4832)59-03-52
Владивосток (423)249-28-31
Волгоград (844)278-03-48
Вологда (8172)26-41-59
Воронеж (473)204-51-73
Екатеринбург (343)384-55-89
Иваново (4932)77-34-06

Ижевск (3412)26-03-58
Иркутск (395)279-98-46
Казань (843)206-01-48
Калининград (4012)72-03-81
Калуга (4842)92-23-67
Кемерово (3842)65-04-62
Киров (8332)68-02-04
Краснодар (861)203-40-90
Красноярск (391)204-63-61
Курск (4712)77-13-04
Липецк (4742)52-20-81
Киргизия (996)312-96-26-47

Магнитогорск (3519)55-03-13
Москва (495)268-04-70
Мурманск (8152)59-64-93
Набережные Челны (8552)20-53-41
Нижний Новгород (831)429-08-12
Новокузнецк (3843)20-46-81
Новосибирск (383)227-86-73
Омск (3812)21-46-40
Орел (4862)44-53-42
Оренбург (3532)37-68-04
Пенза (8412)22-31-16
Россия (495)268-04-70

Пермь (342)205-81-47
Ростов-на-Дону (863)308-18-15
Рязань (4912)46-61-64
Самара (846)206-03-16
Санкт-Петербург (812)309-46-40
Саратов (845)249-38-78
Севастополь (8692)22-31-93
Симферополь (3652)67-13-56
Смоленск (4812)29-41-54
Сочи (862)225-72-31
Ставрополь (8652)20-65-13
Казахстан (772)734-952-31

Сургут (3462)77-98-35
Тверь (4822)63-31-35
Томск (3822)98-41-53
Тула (4872)74-02-29
Тюмень (3452)66-21-18
Ульяновск (8422)24-23-59
Уфа (347)229-48-12
Хабаровск (4212)92-98-04
Челябинск (351)202-03-61
Череповец (8202)49-02-64
Ярославль (4852)69-52-93